

# Fabricated Way Wipers

## Gortite® Fabricated Buna Way Wipers

- Ideal for low to moderate volumes and maintenance applications.
- Fabricated from corners and straight lengths of molded Buna N rubber.
- **Type A** — For heavy chip loads and coolants. Fully enclosed in a metal channel with spring-steel chip guard.
- **Type B** – Large wiping edge for heavy coolant applications.
- Both styles supplied with mounting plate attached for easy installation.

Other styles are available — please see the profiles at right. If what you need is not shown here, Gortite® can make most any shape. Contact your Gortite® representative for further information.

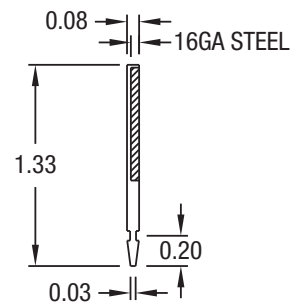
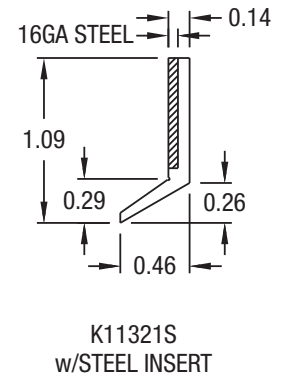
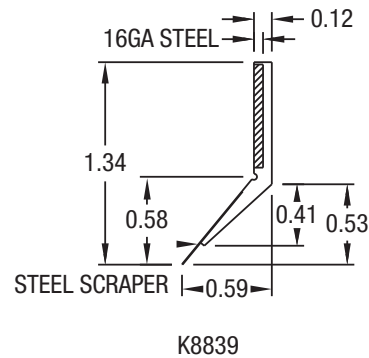
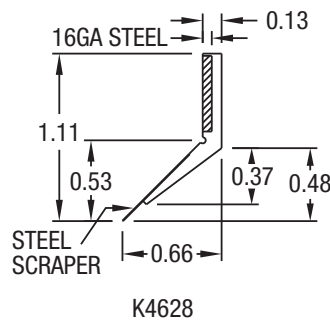
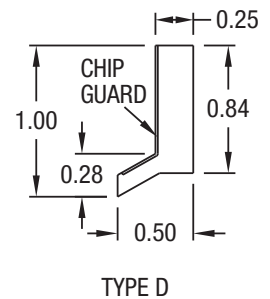
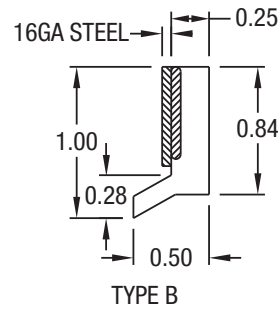
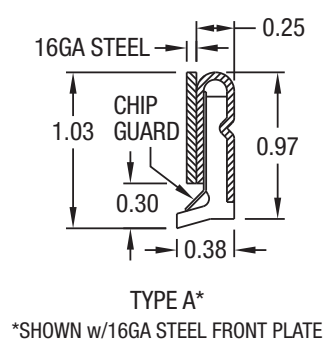

# How to Order Molded & Fabricated Way Wipers

Date: \_\_\_\_\_ For Quotation Only: \_\_\_\_\_ Address: \_\_\_\_\_  
 Order Number: \_\_\_\_\_  
 Company Name: \_\_\_\_\_ City: \_\_\_\_\_ State/Prov. \_\_\_\_\_  
 Contact: \_\_\_\_\_ Country: \_\_\_\_\_ Zip/Postal Code: \_\_\_\_\_  
 Quantity of wipers needed: \_\_\_\_\_ Telephone: \_\_\_\_\_ Fax: \_\_\_\_\_  
 E-Mail: \_\_\_\_\_

If you are designing from existing ways, please provide exact dimensions and include drawings (DWG or DXF files preferred) with all dimensions and outside interferences.

## 1. Molded Wipers

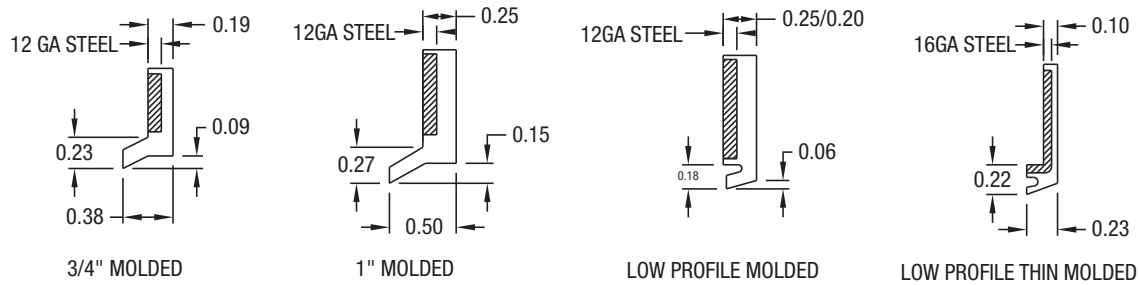

For Custom-Engineered Cross Section, please supply a sketch, drawing or CAD file (DWG or DXF file format preferred)

- 1"  .75"  LP  LP Thin  Custom-Engineered Cross Section

Note: 1", .75" and LP wiper profiles are standard. Custom profiles are available.

- Chip Guard  Wiper drawings enclosed (DWG or DXF files preferred)

- Samples enclosed

Notes: Mold charges apply to all new molded wiper orders. If sending samples, please contact Gortite® for a Return Authorization Number.

- Application:  Wet  Dry If dry, wiper must be fabricated.

Machine Make \_\_\_\_\_

Model/Part# \_\_\_\_\_

- Existing wiper in our factory  New machine design

Gortite® can make most any shape. Contact Gortite® for further information.

## 2. Fabricated Wipers

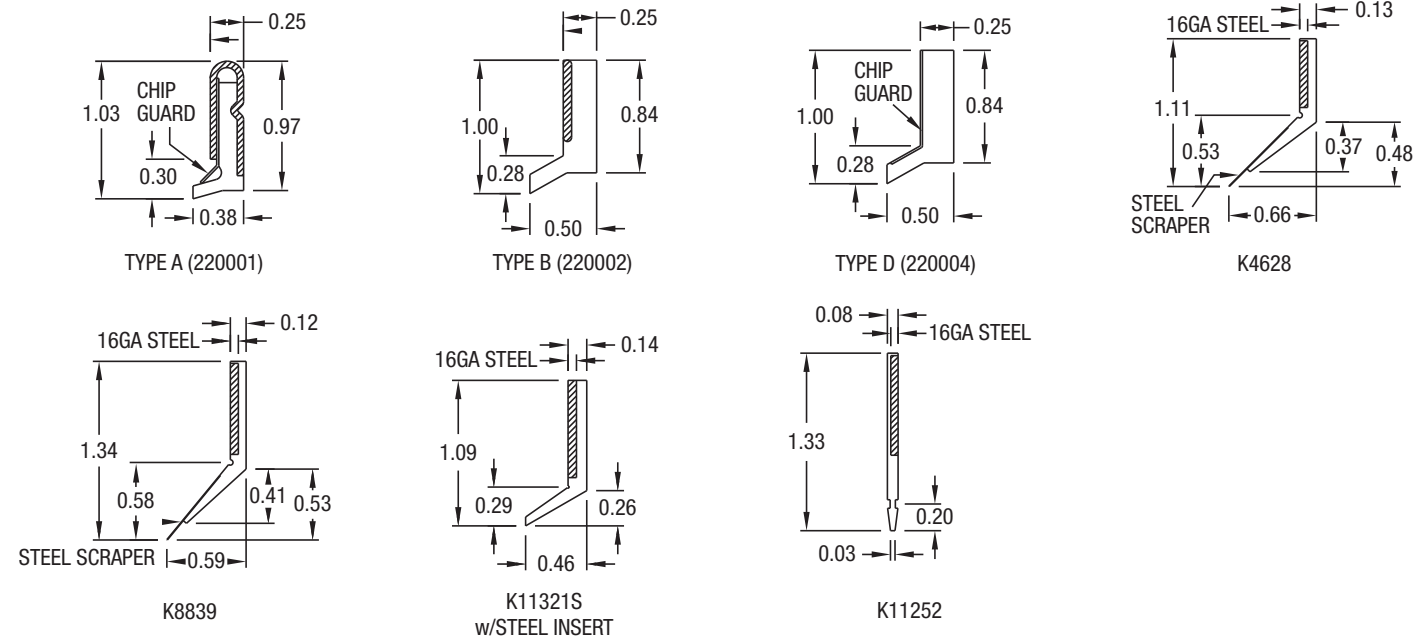

- Type A 220001  Type B 220002  Type D 220004

- Type K4628  Type K8839

- Type K11321S with Steel Insert

- Type K11252

- Chip Guard  Wiper drawings enclosed (DWG or DXF files preferred)

- Samples enclosed

- Application:  Wet  Dry If dry, wiper must be fabricated.

What is the machine? Make \_\_\_\_\_

Model/Part# \_\_\_\_\_

- Existing wiper in our factory  New machine design

Notes: If sending samples, please contact Gortite® for a Return Authorization Number. Gortite® can make most any shape. Contact Gortite® for further information.

Please fax or e-mail the completed form to the number/address shown.